

# Technical Data

## ENGINES

### 1.8 litre petrol

Fuel	UNLEADED 95 RON <sup>†</sup> to EN 228 specification is recommended
Capacity	1796 cm <sup>3</sup>
Firing order	1-3-4-2
Idle speed	750 ± 50 rev/min
Bore	80 mm (3.15 in)
Stroke	89.3 mm (3.52 in)
Number of cylinders	4 in-line
Compression ratio	10.5:1
Ignition system	MEMS3 breakerless, electronic
Spark plugs	GSP 66527
Spark plug gap	1.0 mm ± 0.05
† Unleaded fuels of 95 - 98 RON can be used.	

### 2.5 litre petrol

Fuel	UNLEADED 95 RON <sup>†</sup> to EN 228 specification is recommended
Capacity	2497 cm <sup>3</sup>
Firing order	1-6-5-4-3-2
Idle speed	750 ± 50 rev/min
Bore	80 mm (3.15 in)
Stroke	82.8 mm (3.26 in)
Number of cylinders	6 V-arrangement
Compression ratio	10.5:1
Ignition system	Siemens engine management system
Spark plugs	GSP 66527
Spark plug gap	1.0 mm ± 0.05
† Unleaded fuels of 95 - 98 RON can be used.	

# Technical Data

## 2.0 litre diesel

Fuel	Diesel to EN 590 specification
Capacity	1950 cm <sup>3</sup>
Firing order	1-3-4-2
Idle speed	780 ± 50 rev/min
Bore	84.0 mm (3.31 in)
Stroke	88.0 mm (3.46 in)
Number of cylinders	4 in-line
Compression ratio	18.0:1

## ELECTRICAL

Battery type: 1.8 Petrol engine 2.5 Petrol engine Diesel engine	H5 sealed for life H6 sealed for life H6 or H7, sealed for life, dependent on territory
Battery rating: 1.8 Petrol engine 2.5 Petrol engine Diesel engine	55 amp/hr 75 amp/hr 75 amp/hr (H6), 80 amp/hr (H7)
Voltage and polarity	12 V, negative (-) earth

# Technical Data

## WHEELS & TYRES

### Wheel size and type

Type	Size
Steel wheels	5.5J x 15
Alloy wheels:	
15" wheels	5.5J x 15
16" wheels	6.0J x 16
17" wheels	7.0J x 17
Road wheel nut torque	115 Nm
Spare wheel nut torque	45 Nm

### Tyre specification

Wheel size	Tyre
5.5J x 15 (steel & alloy)	195/80 R15 'Multi terrain' tyre
6.0J x 16 (alloy)	215/65 R16 'Multi terrain' tyre
7.0J x 17 (alloy)	225/55 R17 'Multi terrain' tyre

## TYRE PRESSURES

Driving conditions (all tyre sizes)	Tyre pressures - bar (lbf/in <sup>2</sup> )			
		1.8 Petrol	2.5 Petrol	2.0 Diesel
<b>Normal driving conditions</b> (up to 4 passengers and luggage)	Front	2.1 (30)	2.1 (30)	2.1 (30)
	Rear	2.1 (30)	2.1 (30)	2.1 (30)
<b>Maximum Gross Vehicle weight</b>	Front	2.1 (30)	2.1 (30)	2.1 (30)
	Rear	2.1 (30)	2.1 (30)	2.1 (30)
<b>Towing</b>	Front	2.1 (30)	2.1 (30)	2.1 (30)
	Rear	2.1 (30)	2.1 (30)	2.1 (30)

# Technical Data

## CAPACITIES

Fuel tank (usable)	59 litres (13 gallons)
Engine oil (and filter) refill:	
1.8 Petrol engines	4.5 litre (7.9 pints)
2.5 Petrol engines	5.2 litre (9.2 pints)
2.0 Diesel engines	6.8 litre (12 pints)
Manual gearbox fill from dry:	
1.8 Petrol engines	2.2 litre (3.9 pints)
2.0 Diesel engines	1.6 litre (2.8 pints)
Automatic gearbox refill:	
2.5 Petrol engines	4.0 litre (7.0 pints)
2.0 Diesel engines	4.0 litre (7.0 pints)
Cooling system fill from dry:	
1.8 Petrol engines	5.8 litre (10.2 pints)
2.5 Petrol engines	7.8 litre (13.7 pints)
2.0 Diesel engines:	
- Manual transmission	7.25 litre (12.8 pints)
- Automatic transmission	7.5 litre (13.2 pints)
Washer reservoir	4.0 litres (7 pints)

# Technical Data

## DIMENSIONS

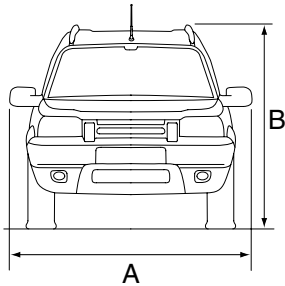

H3485

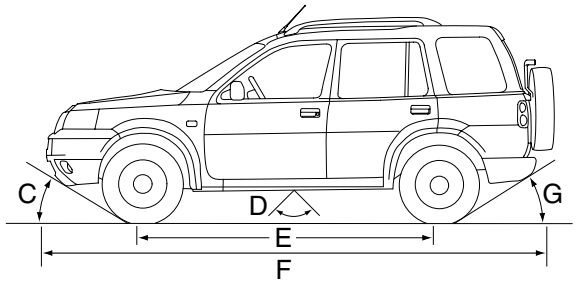

*5-door model illustrated*

F	Overall length (inc. 195/80 spare wheel/tyre): 1.8 Petrol & 2.0 Diesel models 2.5 Petrol models	4368 mm (14 ft 4 in) 4433 mm (14 ft 6.5in)
F	Overall length (inc. 215/65 spare wheel/tyre): 1.8 Petrol & 2.0 Diesel models 2.5 Petrol models	4382 mm (14 ft 4.5 in) 4459 mm (14 ft 7.5 in)
A	Overall width (inc. mirrors)	2068 mm (6 ft 9.4 in)
	Overall height†(excl. roof bars and cross rails)	1708 mm (5 ft 7.2 in)
B	Overall height† (inc. roof bars and cross rails): - 3 door - 5 door	1808 mm (5 ft 11.2 in) 1828 mm (5 ft 11.9 in)
E	Wheelbase	2557 mm (8 ft 4.7 in)
	Ground clearance (minimum)†	186 mm (7.3 in)
	Wading depth (maximum)	400 mm (15.7 in)
C	Max. approach angle†	30.5°
G	Max. departure angle (with towbar)†	23.6°
G	Max. departure angle (without towbar)†	33.9°
D	Max. breakover angle	24°
	† At EEC kerb weight	

# Technical Data

## TOW BAR DIMENSIONS

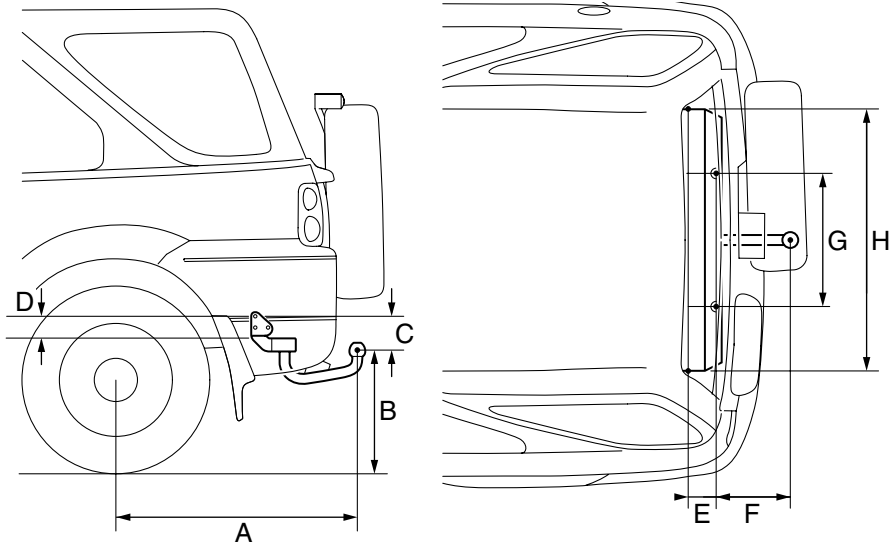

H2717

A	Wheel centre to centre of towball	892 mm
B	Ground to centre of towball	423 mm
C	Centre of inner attachment points to centre of towball	126 mm
D	Centre inner attachments to centre outer attachments	79 mm
E	Centre inner attachments to centre outer attachments	118 mm
F	Centre inner attachments to centre of towball	265 mm
G	Distance between centres of inner attachments	500 mm
H	Distance between centres of outer attachments	990 mm
<i>Dimensions refer to towing equipment officially released by Land Rover</i>		

# Technical Data

## STEERING GEOMETRY

Track:	
- Front	1534 mm (60.4 in)
- Rear	1545 mm (60.8 in)
Turning circle	11.6 m (38 ft 1.2 in)
Steering wheel turns lock to lock	3.16
Wheel alignment:	
- Front (toe out)	20' ± 15"
- Rear (toe in)	20' ± 15"

## WEIGHTS

<b>Approximate unladen vehicle weight (full fuel tank, excluding options):</b>	
- Petrol models	1410 - 1620 kg (3109 - 3572 lb)
- Diesel models	1540 - 1635 kg (3395 - 3605 lb)
<b>Max gross vehicle weight:</b>	
- 1.8 Petrol models	2040 kg (4497 lb)
- 2.5 Petrol models	2060 kg (4542 lb)
- 2.0 Diesel models	2080 kg (4586 lb)
<b>Max. rear axle load:</b>	
- Petrol models	1120 kg (2470 lb)
- Diesel models	1120 kg (2470 lb)
<b>Max. front axle load:</b>	
- 1.8 Petrol models	1050 kg (2315 lb)
- 2.5 Petrol models	1080 kg (2381 lb)
- 2.0 Diesel models	1100 kg (2425 lb)

# Technical Data

## TOWING WEIGHT

<b>Max trailer weight:</b>	
- Petrol models	2000 kg (4410 lb)
- Diesel models	2000 kg (4410 lb)
<b>Max nose weight†:</b>	
- Petrol models	140 kg (310 lb)
- Diesel models	140 kg (310 lb)
<b>Gross train weight (maximum weight of vehicle plus trailer):</b>	
- 1.8 Petrol models	3840 kg (8466 lb)
- 2.5 Petrol models	3860 kg (8510 lb)
- 2.0 Diesel models	3880 kg (8554 lb)
Max roof rack load - all models	75 kg (165 lb)
† To increase stability, it is recommended that you adjust the nose weight to the maximum limit, when loading to the maximum trailer weight.	

**NOTE:** If the trailer weight exceeds 1800 kg, the vehicle payload must be restricted (ie. to less than the Gross Vehicle Weight) to ensure the loaded combination is within the Gross Train Weight limit.

# Technical Data

## FUEL CONSUMPTION

The fuel consumption figures shown below have been calculated using a standard testing procedure (the new EC test procedure from Directive 93/116/EC), and produced in accordance with The Passenger Car Fuel Consumption (Amendment) Order 1996. Under normal use, a car's actual fuel consumption figures may differ from those achieved through the test procedure, depending on driving technique, road and traffic conditions, environmental factors, vehicle load and condition.

### Fuel consumption figures

	URBAN		EXTRA-URBAN		COMBINED	
	mpg	l/100km	mpg	l/100km	mpg	l/100km
1.8 Petrol manual	20.8	13.6	33.3	8.5	27.3	10.4
2.5 Petrol automatic	16.5	17.2	29.1	9.7	22.7	12.4
2.0 Diesel manual	31.0	9.1	42.2	6.7	37.2	7.6
2.0 Diesel automatic	25.2	11.2	39.6	7.1	32.7	8.6

### Urban cycle

The urban test cycle is carried out from a cold start and consists of a series of accelerations, decelerations and periods of steady speed driving and engine idling. The maximum speed attained during the test is 31 mph (50 km/h) with an average speed of 12 mph (19 km/h).

### Extra-urban cycle

The extra urban test cycle is carried out immediately after the urban test. Approximately half of the test comprises steady-speed driving, while the remainder consists of a series of accelerations, decelerations and engine idling. The maximum test speed is 75 mph (120 km/h) and the average speed 39 mph (63 km/h). The test is carried out over a distance of 4.3 miles (7 km).

### Combined

The combined figure is an average of the urban and extra-urban test cycle results, which has been weighted to take account of the different distances covered during the two tests.

**NOTE:** *These figures should not be compared with figures produced using the ECE/EEC procedure previously required by The Passenger Car Fuel Consumption Order 1983. Because of the changes in test procedure, even the urban figures would differ if the same car were subjected to both tests.*

