

Rear seats

FOLDING THE REAR SEATS

⚠WARNING

Never allow passengers to ride in the cargo area. In a collision, people riding in these areas are more likely to be seriously injured or killed. Do not allow anyone to ride in any area of your vehicle that is not equipped for passengers. Be sure everyone in your vehicle is in a seat and using their seat belt properly.

⚠WARNING

In a collision or sudden stop, unsecured objects could be thrown inside the vehicle striking and injuring occupants. Always properly store and secure cargo and other objects in the vehicle.

FOLDING THE SEATS (5 seat vehicle)



E134913

Note: Some 5-seat models are fitted with the same type of seat as the 7-seat model.

The split fold rear seat can be folded completely to accommodate large loads, or partially to accommodate large loads and still retain seating for passengers.

To fold part or all of the seat:

1. Fully lower the head restraints.
2. Pull the strap on the required cushion(s), to raise to the vertical position.
3. Pull the seat backrest release lever(s), then lower the backrest(s) until locked into place.

RAISING THE SEATS (5 seat vehicle)**⚠WARNING**

Always check that the locking mechanism is fully engaged after raising the backrest. If the backrests are not fully locked in place, red markers will be visible around the backrest levers.

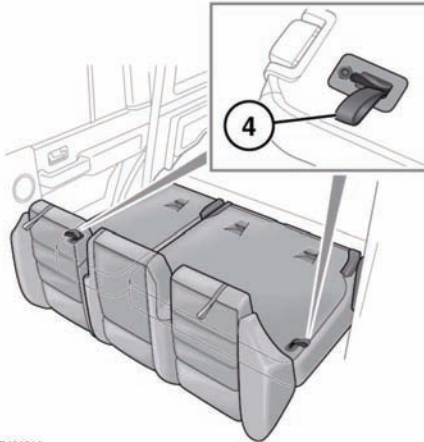

E134914

Pull the strap (4) vertically to unlock the seats, then raise the seats by following the lowering process in reverse.

FOLDING THE SEATS (7 seat vehicle)

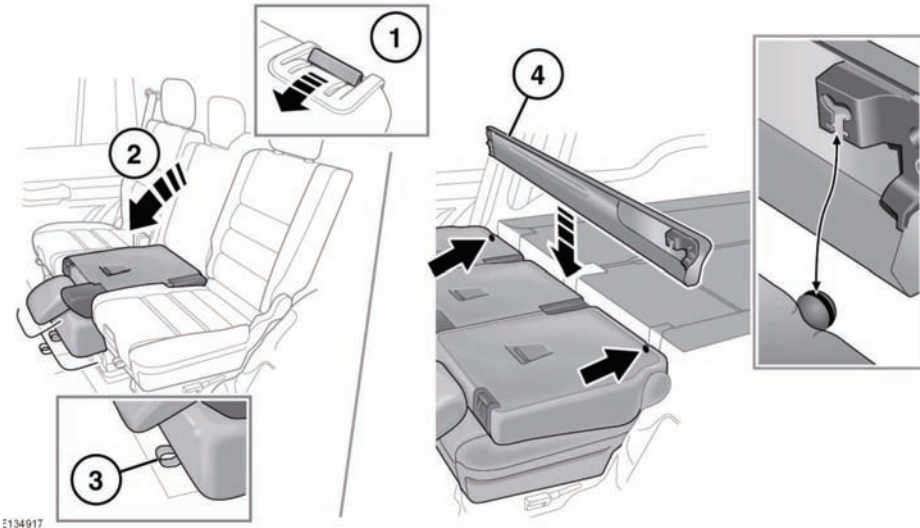

One of the seats may be folded to form a table for the other two seats, or all three seats may be folded forward to extend the loadspace. A seat may also be folded to gain access to the 3rd row seats.

Note: The rear seats may not be folded if the front seats are in their furthest rearward position.

Note: The center backrest must always be folded first.

1. Pull the backrest lever forwards.
2. Fold the backrest forwards into the table fold position.
3. Pull the strap at the front of the seat and press down to fold into the loadspace extension position.
4. The loadspace cover may be stowed as shown behind the folded seats.

RAISING THE SEATS (7 seat vehicle)

⚠ WARNING

Always check and physically test the cushions and backrest are secure before driving. If the backrests are not fully locked in place, red markers will be visible around the backrest levers. Unsecured seat cushions and backrests may not properly restrain an occupant during a collision or sudden stop.

NOTICE

Do not attempt to raise the seats when the loadspace cover is stowed behind them. Damage to the loadspace cover will result.

Note: The center backrest should always be raised last.

1. Pull the strap at the front of the cushion.
2. Grasp the top and bottom of the backrest, lift the seat and return it to the table fold position.
3. Push the release lever forward.

- Pull the backrest up and push into place. When fully home the latching mechanism will click.

ACCESS POSITION (7 seat vehicle)

⚠ WARNING

The vehicle must not be driven with the rear seats in the access position. Motion of the vehicle could cause the backrest to fall forwards suddenly, causing injury.

To access the third row of seats by this method, the headrest on the second row seat must first be fully lowered.

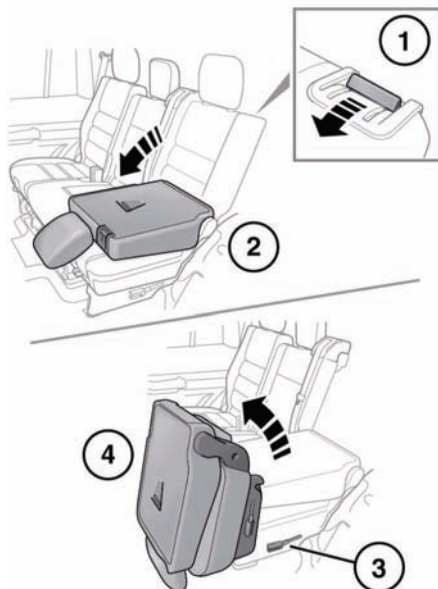

E134918

- Pull the backrest lever forwards.
- Lower the backrest into the table fold position.
- Pull the access lever on the side of the seat.
- Tilt the seat forwards.

To return the seat to the upright position, lower the seat until the access lever re-engages, then pull the backrest lever and return the backrest to the upright position.

Note: A second row seat cannot be moved directly from the loadspace position to the access position. The backrest must first be returned to the table fold position.

⚠ WARNING

When returning the seat from the access position, ensure the area under the seat is clear from obstructions that may prevent the seat from locking securely in place.

⚠ WARNING

Always check and physically test the cushions and backrest are secure before driving. If the backrests are not fully locked in place, red markers will be visible around the backrest levers. Unsecured seat cushions and backrests may not properly restrain an occupant during a collision or sudden stop.

THIRD ROW SEATS (7 seat vehicle)

⚠ WARNING

Beware of trapping fingers when raising and lowering the third row seat.

NOTICE

Ensure nothing has been left under the third row seat, or in the footwell when folding down the seat, as this could cause damage to the item or the seat.

NOTICE

Do not attempt to raise the third row seats when the loadspace cover is stowed behind the second row seats. Damage to the loadspace cover or the seats may result.

It is possible to fold the third row seats flat.

FOLDING AND RAISING THE THIRD ROW SEATS

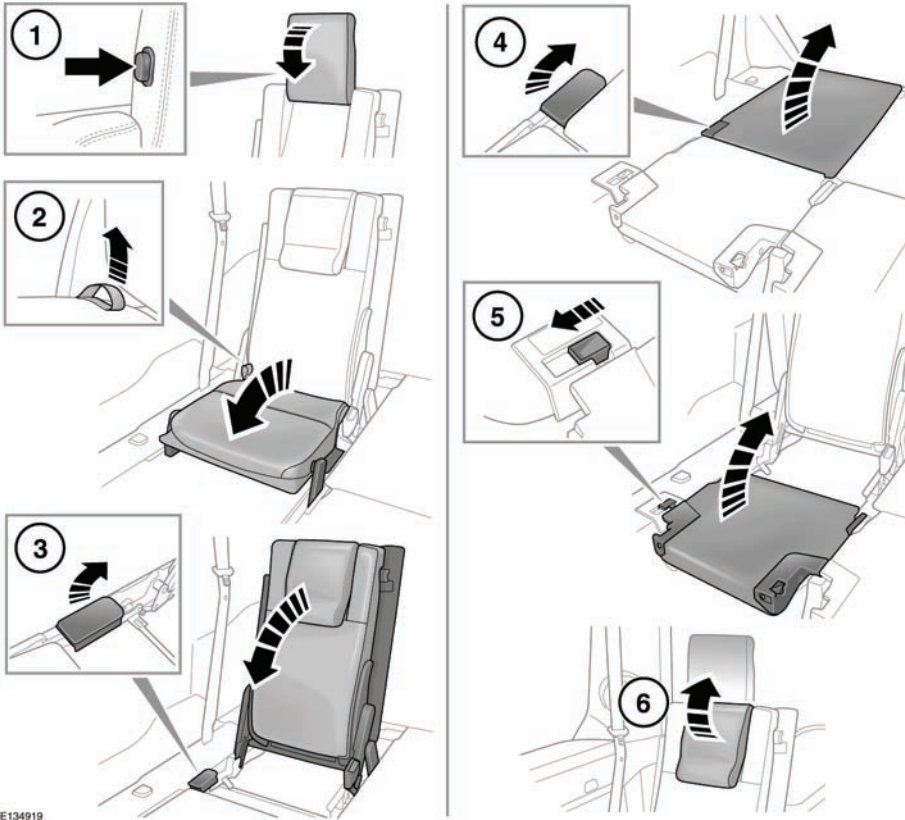

E134919

⚠ WARNING

To reduce the risk of neck injury in the event of a collision or sudden stop, the head restraint must always be raised when a third row seat is occupied.

1. **To fold:** Press the head restraint release button, and fold the head restraint fully downwards.

2. Pull up the release strap (located at rear of cushion) to release the seat. This may require moderate force. Fold the cushion fully forwards until it latches into position.
3. Pull up the backrest lever and fold the backrest fully forwards, until it latches into position in the loadspace floor.
4. **To raise:** Pull backrest lever to release the backrest, and raise to the upright position. Ensure it is fully latched into position.

5. Release the catch to raise cushion. Push into place, ensuring the cushion is latched to the backrest.
6. Raise the head restraint until it latches into position.