

## LOCKING AND ARMING THE ALARM

### **⚠**WARNING

Before exiting the vehicle, always ensure that the gear selector is in the Park (P) position, the engine is turned off, the parking brake is applied and the Smart Key is removed from the vehicle.

Press the lock button on the Smart Key briefly, to lock the vehicle and activate the perimeter alarm. The hazard warning lamps will flash to confirm.

The perimeter alarm will sound if:

- The hood, tailgate or a door are opened.
- The vehicle battery is disconnected.
- An attempt is made to disconnect the alarm siren.

## DOOR LOCK AND RELEASE LEVERS

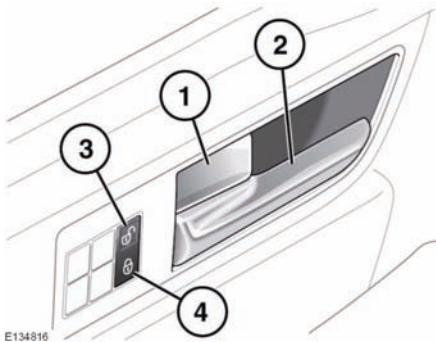

From inside the vehicle, all the doors can be locked by pressing either the driver or passenger lock lever (1).

Each rear door can be individually locked by pressing the appropriate locking lever.

To unlock and open a front door, pull the door handle (2). To unlock and open a rear door, first operate the lock lever, then pull the door handle.

**Master lock/unlock buttons:** To lock (4) or unlock (3) the vehicle press the respective button on the door.

**Note:** The master unlock button is inhibited when the vehicle is locked with the Smart Key.

## MISLOCK

When attempting to lock the vehicle, if one or more of the doors, the hood or the tailgate are not fully closed, the vehicle will fail to lock and the horn will emit two tones. The vehicle will not fully lock until all doors, the hood and the tailgate are completely closed.

## KEYLESS LOCKING

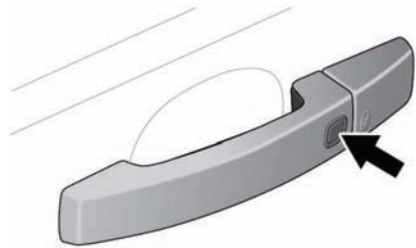

The vehicle will not lock automatically.

To lock the vehicle press the keyless locking button (arrowed) on the door handle once. The hazard warning lamps will flash once to confirm. In some markets an audible warning will sound.

**Note:** Keyless locking will only activate if the Smart Key is detected outside the vehicle. If no Smart Key is present when the button is pressed, two warning tones will sound.

### **DEACTIVATING THE ALARM WHEN TRIGGERED**

If the alarm has been triggered it can be deactivated by pressing the Smart Key unlock button, or by positioning the Smart Key underneath the steering column (see **77, IF THE ENGINE FAILS TO START**).