

SUPERVISOR SCREEN

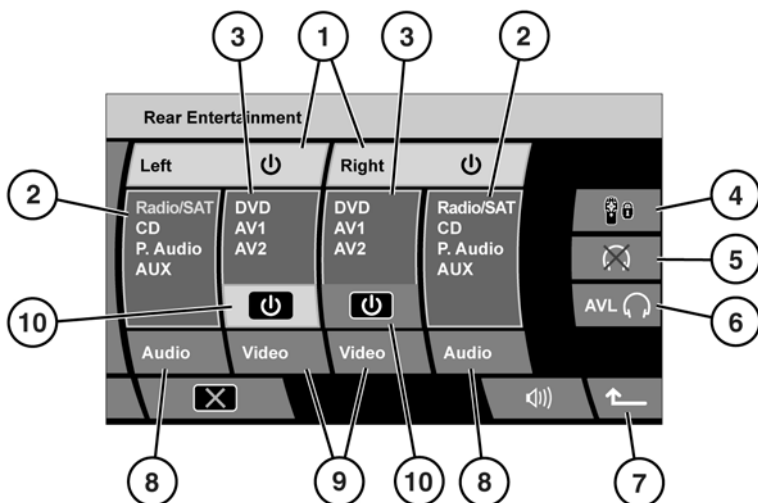

SL1746



WARNING: Do not adjust the touch screen controls, or allow the system to distract the driver, while the vehicle is moving. Driver distraction can lead to accidents, causing serious injury or death.

1. **Left** and **Right** rear screens on/off.
2. Audio source displays.
3. Video source displays.
4. RSE lockout.
5. Headphones mute.
6. **AVL** - Headphones volume limiter.
7. Return to previous screen.
8. **Audio** source selector.
9. **Video** source selector.
10. Video on/off.

Note: The illustration shows all intended audio and video options.

INTRODUCTION TO REAR SEAT ENTERTAINMENT (RSE)

The RSE system consists of two screens. Separate programs can be viewed or heard by rear seat occupants. Supervisory control is made from the front seats. Audio and video programs for each or both sides of the RSE, can be controlled from the Supervisor screen. The RSE remote control can be locked out, headphones can be muted and a volume limit can be set for the headphones.

TURNING ON THE RSE

To switch on a rear screen;

1. From the Home menu, select **Rear Entertainment**.
2. From the Supervisor screen, select **Left**, **Right** or both, as required.

Note: When a rear screen is turned on, the last used audio or video source for that screen will play. If that source is a DVD, then it will resume play at the point it was previously left.



CAUTION: Children should be supervised at all times and view/listen to only media suitable for their age group.

To switch off a rear screen completely, select **Left**, **Right** or both again.

To switch off only the video source to a rear screen, touch the appropriate **Video** on/off soft key. The screen will remain backlit ready to display information and messages. Touch the same soft key to turn the screen on again.

CONTROLLING RSE WITH THE SUPERVISOR SCREEN

When the Supervisor screen is displayed, the RSE remote control will be locked out. No part of the RSE will operate, until it is turned on at the Supervisor screen.

Selecting an audio source:

The Supervisor screen will display a choice of audio sources: **Radio**, **HD Radio** (or **Satellite radio**), **CD**, **P.Audio** and **AUX**.

To select an audio source;

1. Touch an **Audio** soft key repeatedly until the highlight moves to the audio type you require.
2. After 2 seconds without any further selections, the selected audio source will play.

Note: When watching a video source, an alternative audio source can be selected.

Selecting a video source:

The Supervisor screen will display a choice of video sources: **DVD**, **AV1** and **AV2**.

To select a video source;

1. Touch a **Video** soft key repeatedly until the highlight moves to the video type you require.
2. After 2 seconds without any further selections, the selected video source will play.

Note: When a new video source is selected, the audio source will always be synchronised. However, if an alternative audio source is subsequently selected, synchronisation can be achieved again with a long touch of the relevant **Audio** soft key.

Remote control lockout:

The RSE remote control can be locked out, to prevent selections being made.

Touch the RSE lockout soft key. Touch again to reinstate the remote control.

Note: After an ignition cycle and door lock, the RSE lockout soft key defaults to the off state.

REMOTE CONTROL

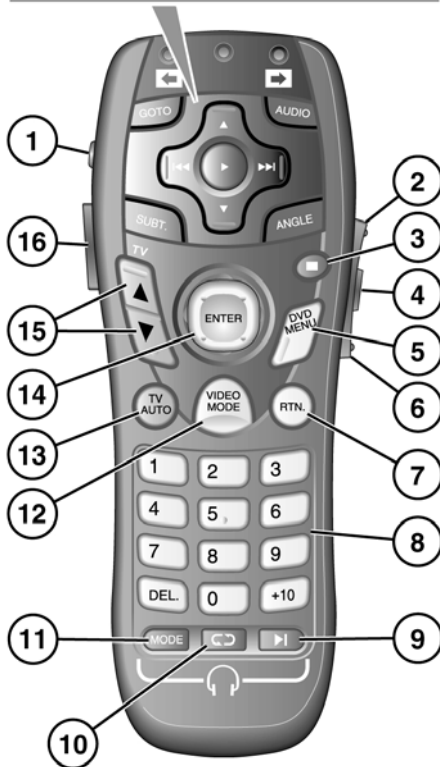
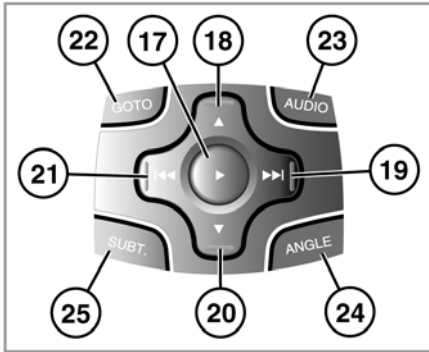

SL1527

1. RSE on/off. Long press to toggle between NTSC and PAL video format.
2. Press to increase the set level.
3. DVD suspend play. Press again to end DVD play.
4. Menu select. Press repeatedly to view the setup choices.
5. DVD menu display.
6. Press to decrease the set level.
7. Press to return to the previous CD or DVD menu.
8. Numeric keypad: Press to select DVD chapters or CD tracks.
9. Radio/CD next station/ track. Long press to search through a CD track.
10. Radio/CD next preset station/CD. Long press to scroll through wave bands.
11. Radio/HD Radio/CD/USB/RSE audio selector. Long press for AUX selection.
12. Press to change video mode: DVD, AV1 and AV2.
13. Not used.
14. DVD menu control. Move left, right, up or down the menu. Press to confirm selection.
15. Not used.
16. Press to illuminate controls.
17. DVD play.
18. DVD next disc up.
19. DVD seek forward/fast forward.
20. DVD next disc down.
21. DVD seek backward/fast backward.
22. GOTO chapter selection and DVD status.
23. Access DVD audio options.
24. Access DVD viewing angle options.
25. Access DVD subtitle options.

Rear seat entertainment

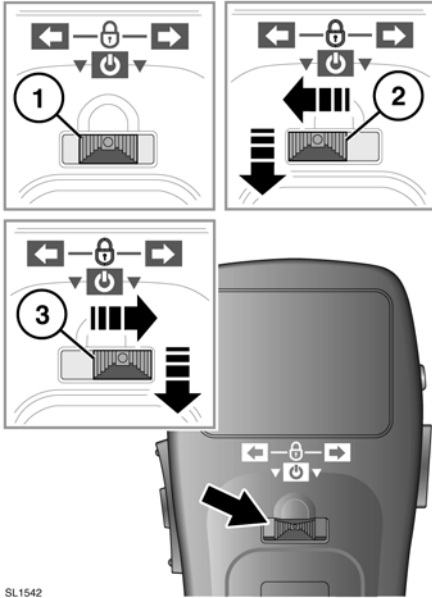

1. Central position - remote control locked.
2. Remote commands for right screen. Press to turn the right screen on/off.
3. Remote commands for left screen. Press to turn the left screen on/off.

Note: Only the video image is turned on/off. The audio signal continues unless another source is selected.

Note: The remote control will not operate if the front supervisor screen is active.

SCREEN SETTINGS

Press button **4** to access the first setting option. Pressing the button repeatedly will scroll through further options.

While the required option is highlighted, the level can be adjusted. Use buttons **2** and **6** to adjust the set level up or down.

Options where levels can be adjusted include:

- BRIGHT (screen brightness).
- COLOR (screen color).
- DIMMER (AUTO, DAY and NIGHT). DAY is the brightest setting. NIGHT is the lowest setting.
- DIMMER LEVEL (fine-tune dimmer settings).

A fifth press of button **4** will access **DISPLAY MODE**. The screen aspect ratio can be adjusted to suit the video media being viewed.

- 16:9 (wide screen).
- 4:3.
- CINEMA (used for films produced for cinema release).
- ZOOM (slightly wider than CINEMA setting).

Reset to defaults

Select to revert all screen display settings to their defaults.

VIDEO SIGNAL FORMAT

When the video format option is highlighted, it is recommended that **AUTO** is selected. This allows the system to determine the correct video format.

NTSC (National Television System Committee) is the format used in North America.

PAL (Phase Alternating Line) format is used in the United Kingdom and other countries around the world.

RSE AUDIO SOURCE SELECTION

To select an audio source press button **11**. Press repeatedly to scroll through the available audio sources. When the required source is highlighted, play will commence. A long press will select **AUX** mode.

Note: *If you want to listen to the soundtrack of a video source such as a DVD, select RSE. The soundtrack can then be listened to with, or without, the video being displayed.*

Radio play:

With radio selected as the audio source, press button **9** to seek up to the next available station. Alternatively, press button **10** to move to the next pre-set station. A long press of button **10** will scroll through and select a radio band.

CD play:

With CD selected as the audio source, press button **9** to skip forward to the next available track. A long press of button **9** will search forward through the track. Alternatively, press button **10** to move to the next CD.

USB:

Use buttons **9** and **10** as for CD play.

RSE VIDEO SOURCE SELECTION

To select a video source press button **9**. Press repeatedly to scroll through the available video sources.

DVD play:

To start DVD play, press button **17**. Press button **3** to pause play. Press **3** again to end play.

To move to the next available disc, press button **18**. To move back to the previous disc, press button **20**.

To seek forward press button **19** and to seek backward press button **21**. Press and hold to fast search.

Some discs allow DVD playback to be started at specified points. To start from a certain chapter for example, access the DVD menu by pressing button **5**. The menu will display any available choices for start point etc.

Note: *The features available from the DVD menu will vary according to the discs inserted. Please refer to the instructions supplied on-screen for more information.*

If an attempt is made to enter a command that is either not available on the disc currently playing, or a command which is available but not at that time, a no entry symbol will appear in the top right corner of the display screen.

Some DVD discs are recorded with additional features that allow subtitles to be displayed, camera angle to be changed and audio choices to be made. If these features are available they can be accessed using the DVD menu button (**5**) and then making the choices/adjustments as required.

Alternatively, the dedicated feature buttons camera angle (**24**), subtitle (**25**) and audio (**23**), can be pressed to access the relevant feature.

DVD audio:

Most DVD discs have a selection of audio effects available. These are accessed by pressing button **23** to scroll through the selections. The selections appear as **AUDIO 1** and **AUDIO 2**.

The main touch screen will display an icon to indicate the audio system in operation.

DVD region codes:

If a DVD with an incorrect region code is inserted into the DVD player, the message **REGION CODE VIOLATION** will be displayed on the video screens.

ON-SCREEN INFORMATION

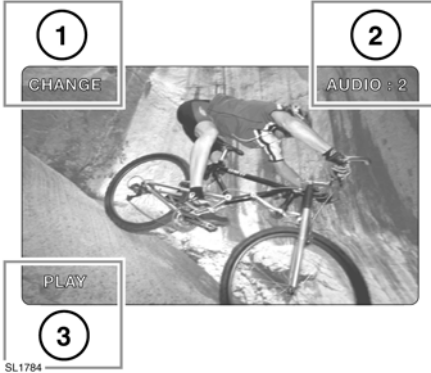

1. CD and DVD feedback and information.
2. Invalid command messages and audio channel information.
3. CD and DVD feedback and information.

REAR PASSENGER AUDIO CONTROLS

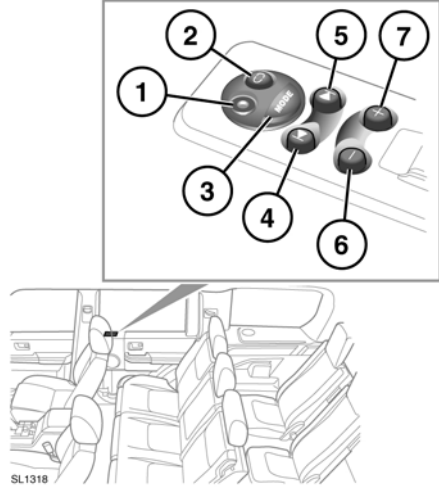

1. 3.5 mm headphone socket.
2. Preset/CD select:
 - During radio play, a short press will select the next preset radio station.
 - During CD play, press and release to select the next CD.
3. Mode control:
 - A long press will select AUX.
 - With Aux selected, press to return to the previous mode.
 - When rear seat entertainment is selected, all adjustments are made through the remote control.

4. Search down:
 - During radio play, press to search down the frequency band for the next station with a good signal strength.
 - During CD play, a short press will start the current track again. A second press will start the previous track.
 - During CD play, a long press will search back through the track being played, until the button is released.
5. Search up:
 - During radio play, press to search up the frequency band for the next station.
 - During CD play, a short press will start the next track.
 - During CD play, a long press will search forward through the track being played, until the button is released.
6. Headphone volume decrease.
7. Headphone volume increase.

With the ignition on, the rear seat controls will operate regardless of whether the audio system is switched on or not. However, the output can only be heard through the headphones.

If rear seat passengers are listening to the same source as the front seat passengers, only the volume can be adjusted at the rear seat controls.

HEADPHONES

Note: Only headphones with a 3.5 mm jack plug socket can be used. To obtain optimum sound quality, use headphones with an impedance of 32 ohms.

Note: When the headphones are not connected, the rear seat controls remain operational. It is still possible to select CD while the radio is playing on the audio unit. CD play will remain operational until the mode control is pressed again.

Note: Adjusting the volume on the audio unit, does not alter the headphone volume. The volume of each controller can be adjusted independently.



WARNING: Always store headphones safely when not in use. Do not leave them unsecured as they may cause injury in the event of sudden braking or impact.